

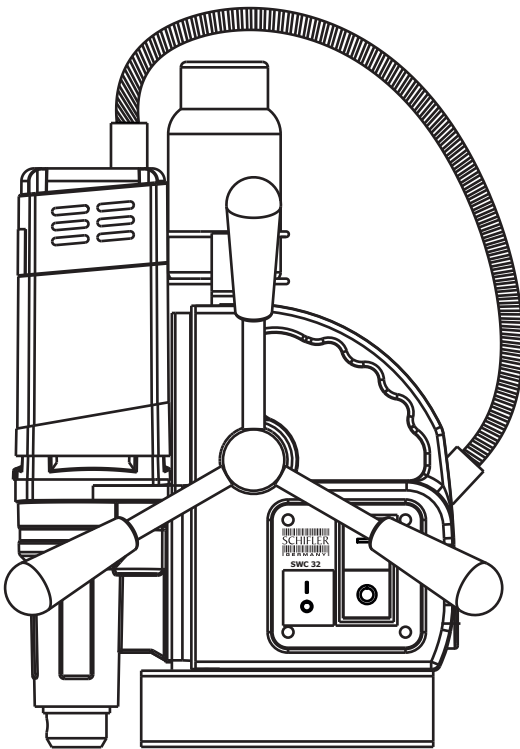

Magnetic Drilling Machine



SWC 32



OPERATING MANUAL

Table of contents

1. Safety Procedures
2. Accessories
3. Description & Technical Data
4. Components Content
5. Operating manual
 - 5.1 How to mount tools or adapters in a Weldon arbor
 - 5.2 Drilling with core drills
 - 5.3 Drilling with twist drills
6. Exploded View
7. Helpful Tips
8. Troubleshooting

UNDERSTANDING SAFETY SYMBOLS



DANGER : The possibility of suffering harm , injury or even death if the situation is not avoided during operation of the machine



WARNING : A statement or event that warns of something or that serves as a cautionary example while using the machine



CAUTION : Care taken to avoid danger or mistakes during operation of the machine



NOTE : A brief record of points or ideas written down as an aid to memory while using the machine

When using magnetic drilling machines please follow the general safety instructions for electric power tools.

			
Please read the manual	Use eye protection	Use ear protection	Use safety helmet
			
Pacemaker warning	Wear appropriate clothing	Disconnect before opening	Use safety chain
			
Warning for electrical shock	Dangerous environment	Don't use in wet places	

WARNING: THIS APPLIANCE MUST BE EARTHED.

1. Always secure the machine with the supplied safety chain before starting to operate, this is to protect the user in case of power failure or breaking loose of the magnet while in use.
2. Always wear safety goggles and ear plugs.
3. Disconnect from the power source when changing cutters or working on the machine.
4. Always ensure cutter retaining screws are secure – they sometimes vibrate loose in use.
5. Regularly clean the work area and machine., remove swarf and dirt, paying particular attention to the underside of the magnet.
6. With a gloved hand, after switching off the power, remove any swarf which might have gathered around the cutter and arbor before proceeding to the next hole.
7. Remove tie, rings, watches and any loose adornments which might entangle with the rotating parts of the machine.
8. Should the cutter get stuck in the workpiece, stop the motor immediately to prevent personal injury. Disconnect from the power source and push and pull the arbor by hand. DO NOT ATTEMPT TO FREE THE CUTTER BY SWITCHING THE MOTOR ON AND OFF.
9. If the machine is accidentally dropped, always thoroughly examine the machine for signs of damage and check that it functions correctly before trying to drill a hole.
10. Regularly inspect the machine and check the nuts and screws are tight.
11. Always ensure when using the machine in an inverted position use special cutting paste or cutting spray which is specially designed for inverted position drilling.
12. Use only spare parts advised by your dealer for magnetic drilling machines.
13. Use the magnetic drilling unit on a clean and flat surface only, to prevent the machine breaking out because of poor clamping force.
14. If you discover any irregularity on machine cables immediately bring the machine to a recognized dealer for a repair or maintenance service.
15. When and in any case if the hole cutter is jammed in work piece during drilling, stop applying downward pressure and switch off the machine, check and take appropriate action to eliminate cause of the jam.

WARNING : DO NOT USE YOUR MAGNETIC DRILL ON THE SAME STRUCTURE WHEN ARC WELDING IS IN PROGRESS. D.C. CURRENT WILL EARTH BACK THROUGH THE MAGNET AND CAUSE IRREPARABLE DAMAGE.

CAUTION DO NOT USE MACHINE OUTSIDE OR IN WET ENVIRONMENT WITHOUT AN (RCD) RESIDUAL CIRCUIT DEVICE. RCD MUST BE USED.

SAFETY INSTRUCTIONS



WARNING

It is mandatory to read and follow all the safety norms, regulations and instructions given in this Guide before you operate the machine to avoid unwanted and fatal accidents. Follow the mentioned workplace safety measures in the guide strictly to ensure your safety against electric shocks or injuries.

SELF PROTECTION

The machine operators must start their work only after the protective glasses, earmuffs and insulated shoes tightened to the legs but must ensure a comfortable movement too. In case the operator has long hair, he must wear a cap suited to the work environment. You must strictly adhere to these rules and prohibit the staff from wearing clothes that are loosely fitted.

Never work towards the maintenance of the circuit board if you haven't followed all the rules mentioned above.

MANDATORY RULES FOR THE WORK PLACE

1. Say no to a messy work environment completely. Keep yourself protected against fatal accidents by keeping the area clean.
2. In case the floor is wet, stop the usage of the drill machine immediately. You will expose yourself to the risk of shock if you don't.
3. Only when the surroundings around are brightly lit, use the machine instead of a dark environment.
4. You must never place flammable material near the machine or avoid using the drill machine in the presence of anything flammable. The Drill machine tends to produce sparks in the process of working, which may cause fire.
5. Children should never be allowed near the drill machine, especially when it is being operated.
6. Nobody should be in the area where the Drill machine is being used by the Operator.

MANDATORY RULES TO ENSURE SAFETY

1. Before you start using the Drill machine, make sure you inspect the condition of the power cord and the plug. Replace them immediately if you see any damage.

2. The power supply should always be in sync with what the equipment requires. Hence, ensure the same while making sure that safety measures for grounding and leakage are made available.
3. Study this manual well to understand the Do's and Don'ts of the Drilling tools. They should be used strictly according to the size specified. The material of the drilling workpiece comes with a magnetized absorption and works better on a smooth surface. Double check that its thickness ranges between 10mm-75mm, without the 0.5mm thickness of Iron scrap and the presence of paint, granular impurities and any other foreign particles should be avoided.
4. If the thickness of the drilling machine is less than 10mm, you must ensure that it is well-supported by iron plates right at the bottom that come with a thickness higher than 10mm. The supporting iron plate must have a base area greater than the drilling machine's area of the magnetic base if you need to improvise the reliability of the capability of the magnetic base's absorption. In case you opt for a supporting iron plate which is thinner than the requirement, you will notice the drilling machine becoming loose in the process of absorption that may lead to unwanted and fatal accidents.
5. Don't press the drill machine too hard as that may lead to an overload, which tends to shorten the life of the magnetic drill. When in use, be extremely attentive to the condition of the magnetic absorption of the drill. Stop using the drill immediately if you notice any instability in the magnetic absorption.
6. Whenever the drill starts to operate or shuts down, ensure that the operating sequence of the motor and magnetic switch has been complied.
7. Do not continuously operate the magnetic base with a full load as that will cast a strong effect negatively on the life of the magnetic base. It may also get heated up to an extent that it may catch fire. Never touch the magnetic base, especially when it is extremely hot as that will cause a serious burn. Turn off the switch and unplug immediately once you stop using the magnetic base.
8. Do not overload the motor for than a total duration of 30 minutes. If done otherwise, it will lead to extreme heat getting generated that will result in a fire or explosion. Switch off the motor when it is not in use.
9. Add a certain amount of coolant to the equipment whenever you

replace the drill. In case you notice a blockage, switch off the motor immediately. However, you must leave the magnetic base power on. The logic behind this process is that in case you shut down the power supply of the magnetic base directly, it may result in the operator suffering from injuries. It will also harm the motor because of the sudden loss of magnetic force of the magnetic base.

10. Whenever the magnetic drilling machine is in use and is suspended either in a vertical or a horizontal position, you must get it fixed with a device that gets attached to the equipment so that it doesn't come down falling caused by the sudden loss of power of the magnetic base. When you choose to drill in an upside-down position, always opt for a cooling method that is reasonable. Say a frank NO to the option of Liquid Cooling method as liquid will easily infiltrate into the equipment and result in leakage of electricity. Instead of Liquid Cooling method, choose Mist Spray Cooling.
11. If a Supplier has provided or approved of the Parts and Tools, only then must you use them as once installed on the equipment, they come with a guaranteed usage safety.
12. Do not remove the drill if the spindle and the drill are in continuous motion. Unplug the drill from the main power supply to change its gear and never touch it with your bare hands.
13. Even when the equipment stops working, never use your bare hands to remove the iron fillings after the drilling process as that can cause injuries.
14. While you use the magnetic drill on a particular workpiece, do not do the process of welding on the same.
15. Use the handle function of the drilling machine to move it from one place to another instead of pulling the power cable.
16. Switch off the main power supply and unplug the drilling machine after the usage. If this is not done and the spindle and the tool continue to rotate, then do not let the operator remove the drill and replace the gear with his bare hands. Make sure you practice this to avoid injuries.
17. The generation of the magnetic field affects devices such as watches, mobile phones and pacemaker installed to regulate the heartbeat. Make sure that the operator takes off the watch and keeps the mobile phone before operating the drilling machine and doesn't have a pacemaker installed in him.

CLEANING AND MAINTENANCE

1. Keep a close check on the bolt of the magnetic drill. It should not be loose and the gap in the spindle should not be too large. The power cable of the drill should be in a good condition. You must make sure that the machine is maintained well.
2. Inspect the carbon brush and change it immediately if you notice that it is worn out.
3. The Lubricating Grease in the Gear Box should be changed by a professional once you have used the drill for three months. Inspect well once the professional finishes to double check that all the parts have been fully lubricated.
4. It is always the After-Sales Service Department or the designated dealer who cater to the maintenance of the drill machine.
5. The operator must clean the magnetic drill after finishing the work, scrub the side where the drill slides while working and apply lubricating oil on the drill for the machine to last longer.
6. Whenever you indulge in the process of cleaning the Drill with compressed air, you must wear Goggles and to protect yourself and the other people around you at the workstation.
7. Switch the machine off and unplug it from the main power socket before you start the process of maintenance and cleaning.

When it comes to the process of Maintenance, Inspection and Repair pertaining to their electrical aspects, only a qualified electrician must be contacted to cater to the task. The qualifications of these electricians change according to their respective countries. They must follow the effective rules put in place when it comes to processing, inspection and the maintenance of a Circuit Board in order to avoid accidents.

ENVIRONMENTAL PROTECTION AND WASTE DISPOSAL

1. Disposal of the old electrical equipment: Make sure you process the product in accordance with EC Directive 2002/96/EC-WEEE, also known as Waste Electrical and Electronic Equipment. In case of doubts or queries, contact the Department of Waste Disposal.
2. Disposal of grease: Follow the instructions given by the lubricant's manufacturer.

OPTIONAL TOOLS & ACCESSORIES

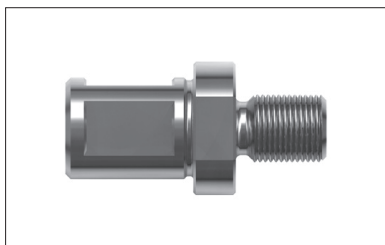

Weldon Drill Chuck Adaptor

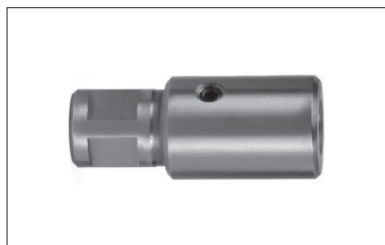

Weldon Tapping Adaptor



Drill Chuck



Weldon Counter Sink



MT 2 / MT 3 Arbour

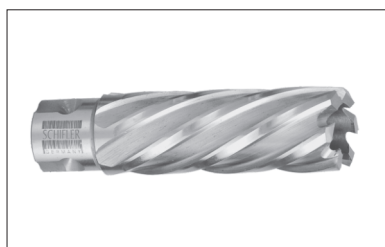

Core Drill



Pilot Pin



Taper Drift

DESCRIPTION & TECHNICAL DATA

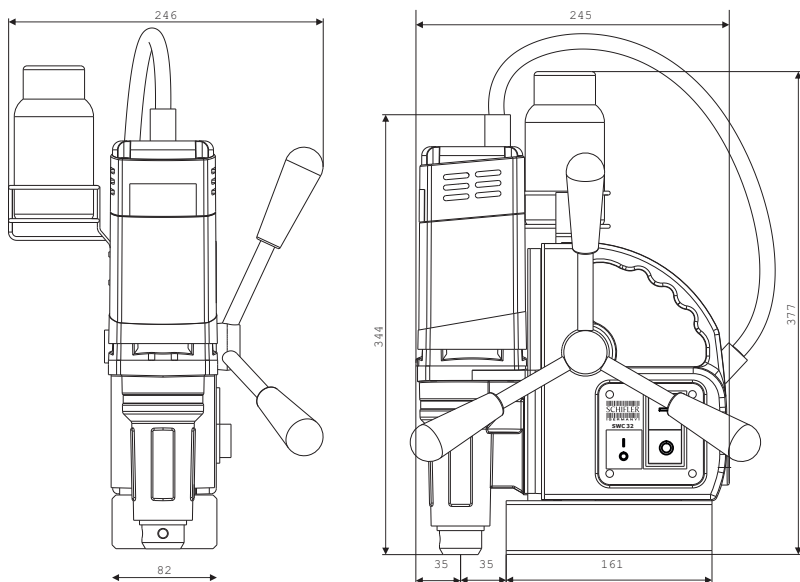

Motor power	1100 watt
Spindle	19 mm (3/4") Weldon
Broach cutter (35 mm length)	ø 12 mm - ø 35 mm
Broach cutter (50 mm length)	ø 12 mm - ø 35 mm
RPM	450 min-1
Weight	10 kg (22.0 lbs)
Magnet power	10000 N
Input supply voltage	220-240 V
Frequency	50-60 Hz

COMPONENTS CONTENT

1. Packing case	1 No.	7. Instruction Manual	1 No.
2. Cooling Bottle	1 No.	8. Magnetic Drill Machine	1 No.
3. Safety Belt	1 No.	9. Pilot Pin 6x50	1 No.
4. 2,5 mm Allen Wrench	1 No.	10. Pilot Pin 8x50	1 No.
5. 4,0 mm Allen Wrench	1 No.		
6. 6,0 mm Allen Wrench	1 No.		

OPERATING MANUAL

5.1 How to mount tools or adapters in a Weldon arbor?

- 1) Make sure the machine is disconnected from the power supply.
- 2) Put the center pilot in the cutter hole.
- 3) Put the cutter or adapter in the arbor, making sure the flat sides are exactly in front of the arbor retaining screws.



- 4) Tighten the retaining screws.
- 5) Check if the center pilot can move inside the cutter (up and down).

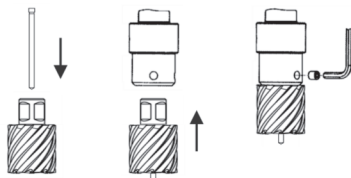

5.2 Drilling with Core Drills

- 1 Place the machine at the desired position



CAUTION : For 100% magnet clamping force you need at least 10 mm of steel. Coatings, paintings and dirt between magnet and workpiece will affect clamping force.

- 2 Switch on the magnet.



- 3 Ensure that the magnetic drilling unit is secure on the working piece.
- 4 Fill the arbor with lubrication/cutting oil in the special meant holes. Always use cutting oil from your dealer.

- 5 Start the motor by pressing the green motor start button (I).



- 6 Start bringing the cutter to the workpiece but handle with care and do not apply too much pressure. The cutter has to find its way in to the material by itself. After 2 mm, the groove of the cut will help the cutter maintain its place and you can increase the power. Still it is not necessary to use a lot of pressure. Too much pressure will cause damage and breakage.

SWC 32 Motor complete / Antriebseinheit

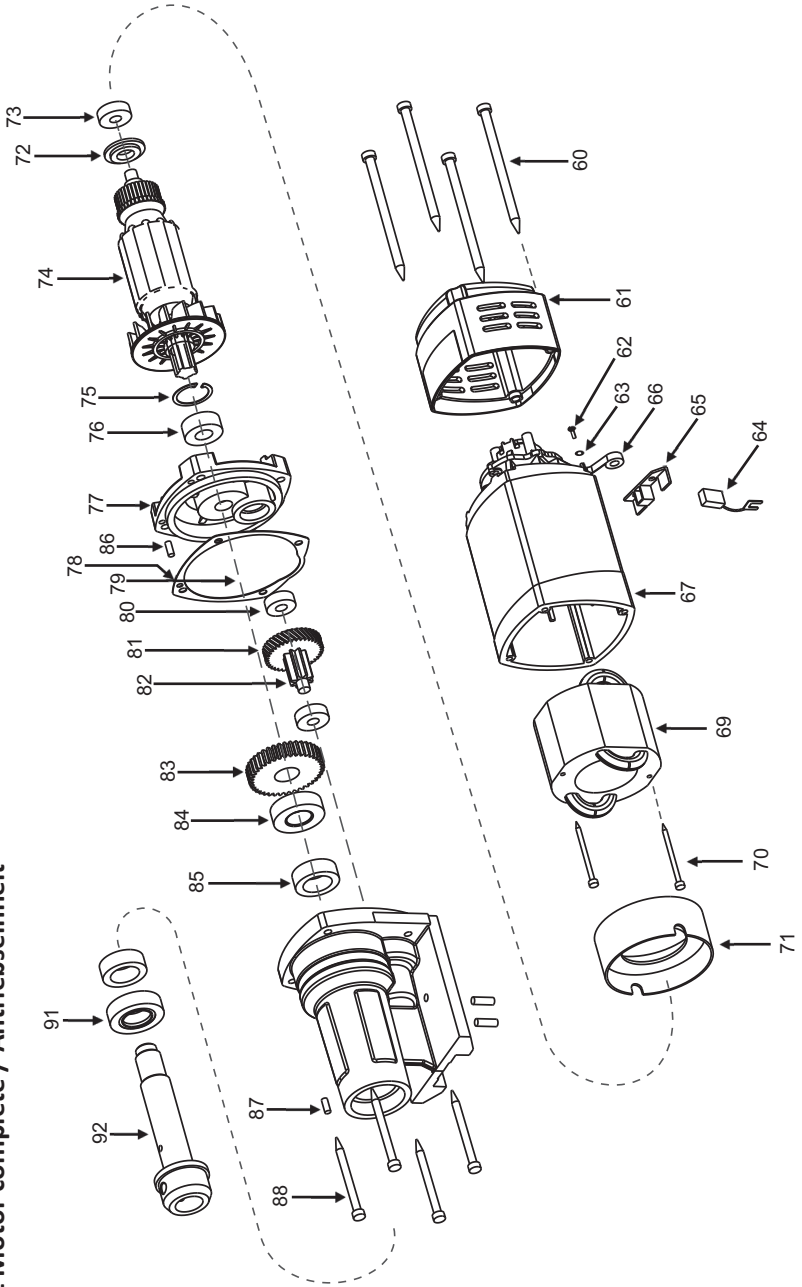

- 7 After the cut is finished the slug will automatically be ejected from the cutter, switch the machine off by pushing the red button(0).
- 8 If the slug gets stuck in the cutter, move the machine to a flat surface. Switch on the magnet and gently bring the cutter down in contact with the surface. This usually allows a slug to straighten and to eject.

WARNING: THE SLUG WILL BE EJECTED AND IS VERY HOT

5.3 Drilling with twist drills

There are several accessories available to be able to use twist drills with your magnetic drill.

- Adapter 19 mm Weldon - ½"x20 UNF
- Adapter 19 mm Weldon – B16 taper connection
- Adapter 19 mm Weldon – B18 taper connection



Weldon Drill Chuck Adaptor



Drill Chuck

These adapters will allow you to attach a drill chuck on to the hole cutter arbor.

Also twist drills with a direct Weldon connection are available (ranging from $\varnothing 6 - \varnothing 12$ mm)

- 1 Place the machine at the desired position
- 2 Switch on the magnet



- 3 Ensure that the magnetic drilling unit is secure on the working piece.
- 4 Apply cutting oil to the twist drill and workpiece. Always use cutting oil from your dealer.
- 5 Start the motor by pressing the green motor start button.



- 6 Start bringing the twist drill to the workpiece but handle with care and do not apply too much pressure. The drill has to find its way in to the material by itself. It is not necessary to use a lot of pressure. Too much pressure will cause damage and breakage.
- 7 After the cutting is finished switch the machine off by pushing the red button.

SWC 32 Motor complete / Antriebseinheit

Part No.	Article	Article	Description	Pcs
60	709311703555	Screw	ST4.8x60	4
61	709311703562	Motor cap	SWC 35	1
62	709311703579	Screw	M4x12	6
63	709311703586	Washer	M4	6
64	709311703593	Carbon brush	18x6.2x9.9 220V	1
65	709311703609	Carbon brush holder	18x6.2x9.9	2
66	709311703616	Spring	5x0.3	2
67	709311703623	Motor shell (black)	SWC 35	1
68	709311703630	Fuse	275V 0.1uf	1
69	709311703647	Field coil	1100W 220V	1
70	709311703654	Screw	ST3.9x62	2
71	709311703661	Air Sleeve	ø75.5xø45x30	1
72	709311703678	Dust Cap		1
73	709311703685	Ball Bearing	608ZZ P6	1
74	709311703692	Armature	1100W 220V	1
75	709311703708	Hole circlip	ø28	1
76	709311703715	Ball Bearing	6001Z P6	1
77	709311703722	Gear box cap	35-85x85x24	1
78	709311703739	Paper gasket seal	ø78x0.5	1
79	709311703746	Shaft circlip	ø10	1
80	709311703753	Ball Bearing	608 P6	2
81	709311703760	Helical gear	Z34mlh9	1
82	709311703777	Pinion	Z8ml.25L45	1
83	709311703784	Straight gear	Z40ml.25h10	1
84	709311703791	Ball Bearing	6003-2RS P6	1
85	709311703807	Skeleton ring	20x30x9	2
86	709311703814	Cylindrical pin	ø4x12	1
87	709311703821	Brass nozzle	M6x16	1
88	709311703838	Screw	ST4.8x50	4
89	709311703845	Gear Box Screw	Ø5 x 25	2
90	709311703852	Gear box	35-85x99x125	1
91	709311703869	Ball Bearing	61904-2RS P6	1
92	709311703876	Drill spindle assembly	ø37xø19.05x136	1

SWC 32 Magnetic frame / Magnetbohrständer

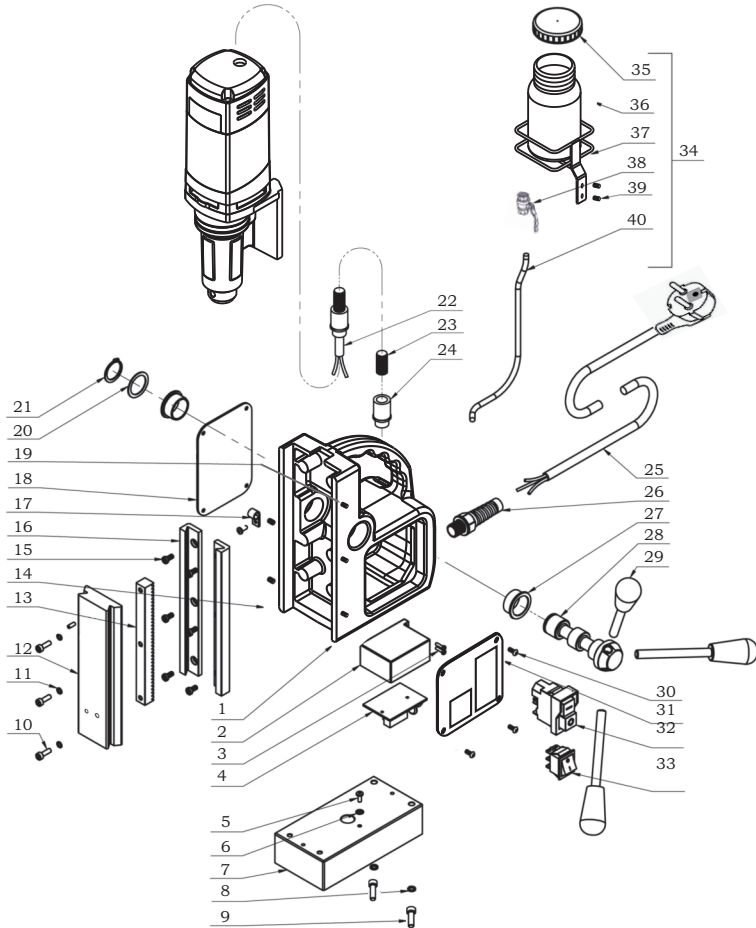

SWC 32 Circuit Diagram / Schaltplan

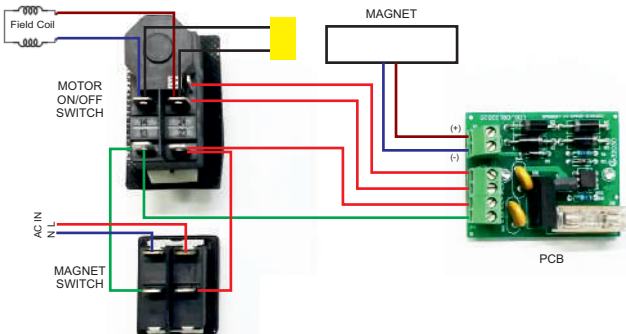

SWC 32 Magnetic frame / Magnetbohrständer

Part No.	Article	Article	Description	Pcs
1	709311703166	Main Body	SWC 32	1
2	709311703173	PCB Box	66x52x30.5	1
3	709311703180	Cross screw	M3x12	2
4	709311703197	PCB	220V	1
5	709311703203	Screws	M4x10	3
6	709311703210	Washer	4	1
7	709311703227	Magnetic base	167x83x43 220V	10
8	709311703234	Spring Washer	M6	4
9	709311703241	Hex Screws	M6x25	4
10	709311703258	Hex Screws	M5x15	2
11	709311703265	Spring Washer	M5	3
12	709311703272	Slide SWC 32	200x60x21	1
13	709311703289	Rack	15x15x170 m1.5	1
14	709311703296	Gasket flat washer-A level	M6	2
15	709311703302	Hexagon round head screws	M5x10-4mm	6
16	709311703319	Slideway (Set of two pcs)	208x22x15.5	2
17	709311703326	R' Clip	6.4	1
18	709311703333	Panel	90x130x2	1
19	709311703340	Hex Screws	M5x8	2
20	709311703357	Flat washer	ø25xø33x1	1
21	709311703364	Shaft circlip - B type	ø25	1
22	709311703371	Cable	220V 10A	0.4
23	709311703388	Nylon wave tube	ø13	0.25
24	709311703395	Straight wave tube fittings	ZT-M16-AD13	2
25	709311703401	Power Cable	250V 16A 1.5mm 3.5m	1
26	709311703418	Torsion Joint	MA16-P-10	1
27	709311703425	sleeve for feed shaft	ø35xø25x15	2
28	709311703883	Feed gear shaft	ø37x108 Z14m1.5	1
29	709311703432	Feed handle	M10x150	3
30	709311703449	Hex Screws	M4x10-	4
31	709311703456	Button panel	90x130x2	1
32	709311703463	Motor ON/OFF Switch	220 V	1
33	709311703470	Magnet Switch	KDC	1
34	709311703487	Coolant Bottle Assembly	600ml	1
35	709311703494	Coolant Bottle Lid	ø58x12	1
36	709311703500	Coolant container	600ml	1
37	709311703517	Bottle Carrier	Steel	1
38	709311703524	Aluminium Valve	ø15.5x37-90	1
39	709311703531	Screw for Coolant Bottle	Ø5x10	2
40	709311703548	PU tube	6x4	0.3 Meter

HELPFUL TIPS



TIP: Do not use your magnetic drill on the same structure when ARC welding is in progress. D.C. current will earth back through the magnet and cause irreparable damage.

TIP: It is recommended that machine is laid to rest every 30 minutes in order to permit grease to run across the gear box.

TIP: When using models with gear and variable speed always select a setting with low transmission ratio and high motor speed, if possible.

TIP: During drilling it is recommended after a certain depth the cutter should be pulled up on free load in order to permit grease to run across the gear box.

TIP: For 100% magnet clamping force you need at least 10 mm of steel. Coatings, paintings and dirt between magnet and workpiece will affect clamping force.

TIP: Most situations which cause problems or question marks have already occurred for other users. Contact Schifler or your dealer to see if a solution exists for your situation. (example: for drilling into non-magnetic material with your magnetic drill, a special vacuum system has been designed).



WARNING: This appliance must be earthed.

WARNING: After drilling the slug will be ejected and is very hot.

WARNING: When drilling in inverted position, cutting oil can enter the motor and can cause irreparable damage.

WARNING: When drilling in inverted position, metal swarf can enter the motor. This can cause irreparable damage and can cause electrical shocks.

WARNING: Steel plates of less than 10 mm thickness, coatings, paints and dirt between magnet and workpiece can affect clamping force and create a possible dangerous situation. Always make sure your magnetic drill is fastened with the supplied safety chain and make sure your machine is sufficient attached to the workpiece to start drilling.



TROUBLESHOOTING

1. If the type of error that you face revolves around the Motor not starting even after pressing the ON/OFF button or the motor tends to stop while it is functioning, following can be the possible causes along with the remedies:
 - a. The plug isn't properly inserted into the socket. Just re-insert the plug.
 - b. The Circuit Breaker has been switched off by accident. Switch it on.
 - c. The torque cut-off has been triggered. You just have to switch the machine off for a few seconds and then switch it on.
 - d. You have missed selecting the direction of rotation. Click on select.
 - e. You haven't switched on the magnetic clamp. Switch it on.
 - f. The machine is over-heated because of which the internal safety switch of the machine is switching it off. Let the machine cool down for some time and then switch it on.
2. If the type of error that you face revolves around the Circuit Breaker tripping in the power distributor, following can be the possible causes along with the remedies:
 - a. The machine has some defective parts. Immediately contact the Customer Service.
 - b. Plenty of appliances have been connected to the same power circuit, resulting in the tripping. Unplug a few of those appliances.
3. If the type of error that you face revolves around the Magnetic clamp not functioning to its best capability, following can be the possible causes along with the remedies:
 - a. You have not switched on the magnet. Switch it on.
 - b. The surface where the machine is placed is not magnetic enough. Change the placement and use a suitable base.
4. If the type of error that you face revolves around the lubrication system not functioning to its best capability or failing to function at all, following can be the possible causes along with the remedies:
 - a. The lubricant is over. Pour the required amount of lubricant into the machine.
 - b. The connecting nipple has gotten clogged. Do a deep cleaning of the tank and the nipple.
 - c. The lubricant tap is jammed or has gotten closed. Open the tap.

Contact the Customer Service immediately if the steps and remedies described above do not solve your problem.

EC DECLARATION OF CONFORMITY

We,
Schifler Werkzeuge and Company Private Limited
Hereby declare under sole responsibility that, the following described
product in our delivered version complies with the appropriate basic
safety and health requirements of the:

Machinery Directive (2006/42/EC)
Low voltage Directive (2014/35/EU)
EMC Directive (2014/30/EU)

Based on its design and its type, as brought into circulation by us.
In case of alteration of machine, not agreed upon by us,
this declaration will lose its validity.

Description of Products

Magnetic Drilling Machine

Models : SWC 32, SWC 35, SWC 35AT, SWC 35 PD, SWC 40, SWC 50 MAX, SWC 50 MAX-T,
SWC 50 PD, SWC 50, SWC 50 WT, SWC 50 PDT, SWC 50 WT SB, SWC 65, SWC 65 WT,
SWC 65 WT SB, SWC 80, SWC 80 WT, SWC 100, SWC 100 WT, SWC 120, SWC 120 WT

Applicable Harmonized Standards:

EN 62841-3-13:2017
EN 62841-1:2015/AC: 2015
EN 60204-1:2018
EN ISO 12100:2010
EN 61000-6-2:2019
EN 61000-6-4:2019

Technical Construction File (TCF) - SCHIFLER /TCF/CE at :
Schifler Werkzeuge and Company Private Limited
B-24, Street No.9, Anand Parbat Industrial Area,
Delhi-110005, India

Year in which CE marking affixed: 2022



Sanjeev Goel
Director

15/04/2022



European Union

Schiffler Werkzeuge & Co.
Bahnhofstraße. 8, 30159, Hannover, GERMANY
Tel.: +49 (0) 511 93639 421
Fax.: +49 (0) 511 93639 300
Email: info@schiffler.de

Asia Pacific

Schiffler Werkzeuge & Co.
B-24, 1st Floor, Street No.9, Anand Parbat
Industrial Area, Delhi-110005, INDIA
Telefon : 011-41044650
Email: india@schiffler.de

Middle East

Schiffler Werkzeuge Middle East FZC
UAQ Free Trade Zone, P.O. Box : 7073,
Umm Al Quwain, U.A.E.
Telefon : +971-568965572
Email : uae@schiffler.de

www.schiffler.de